







Safety

Please read this manual carefully and follow its instructions. Improper use or failure to follow these instructions could result in serious injury, death or property damage. Operators should be instructed in the safe and proper use and maintenance of this product. Keep this manual for future reference.

The following safety precautions call attention to potentially dangerous conditions.

-  **WARNING:** Warnings are used when hazards exist which could result in serious injury, death or property damage if proper precautions are not taken.
-  **CAUTION:** Cautions are used as reminders of safety hazards which could result in personal injury or property damage if proper precautions are not taken.

Installation

-  **CAUTION:** Instruct operators in the safe, proper use and maintenance. Keep this manual for future reference.
-  **WARNING:** Failure to read, understand, and follow these instructions may result in personal injury or death.

A. Track mounting

Carriers are designed to operate on three types of I-beams. They are S4x7.7 lb., S5x10.0 lb., S6x12.5 lb., and 3.25 patent rail. The carriers operate on straight beams without curves or irregular bends.

The I-beam track should be supported at intervals as required for specific circumstances. The means of support must allow 3-5/8 inch minimum wheel clearance for car wheels. Side clearance must be provided and should be not less than one-half the carrier width--dimension A and B in Figure 1. When the system is mounted on moving equipment such as a crane bridge, additional side clearance may be required to allow for side swinging cable loops due to acceleration or deceleration of the equipment.

To insure smooth operation of the cable carriers, joints between I-beam sections should be closely aligned and ground smooth. Bumps and irregularities in the running surface of the I-beam should also be removed. We highly recommend that a single section of I-beam be used when possible.

Figure 1

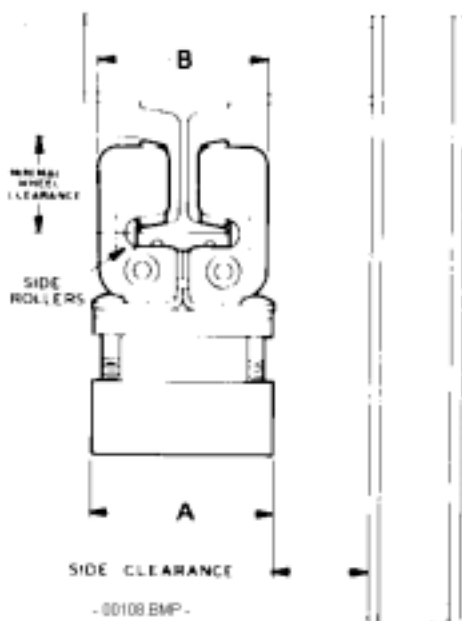

Figure 2

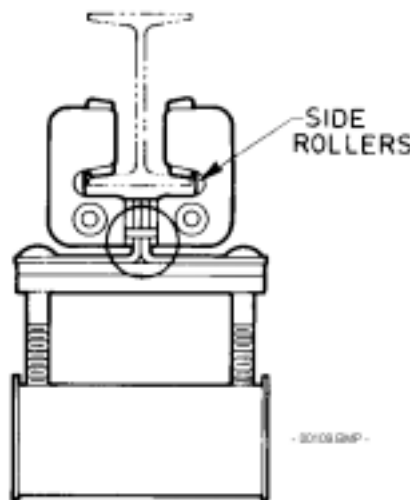
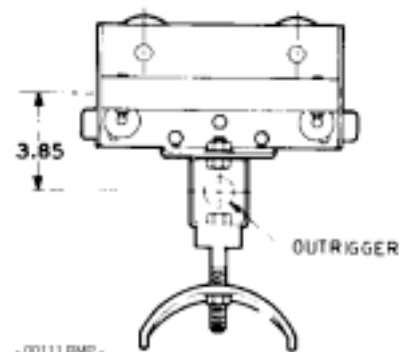

Figure 3



Selection Model No.	A	B
67xx	3.56	--
60xx	5.43	--
63xx	8.12	--
Beam Size		
4x7.7	--	5.00
5x10.0	--	5.38
6x12.5	--	5.75
Pat. Rail 3.25	--	5.62

B. Intermediate car

If the I-beam weight is not otherwise specified in the order, the wheel spacing will be set to fit the S4x7.7 lb. American I-beams.

Wheel spacing can be adjusted by relocation or addition of spacer washers to either side of the wheel mounting bracket. The side rollers should just clear the edge of the I-beam.

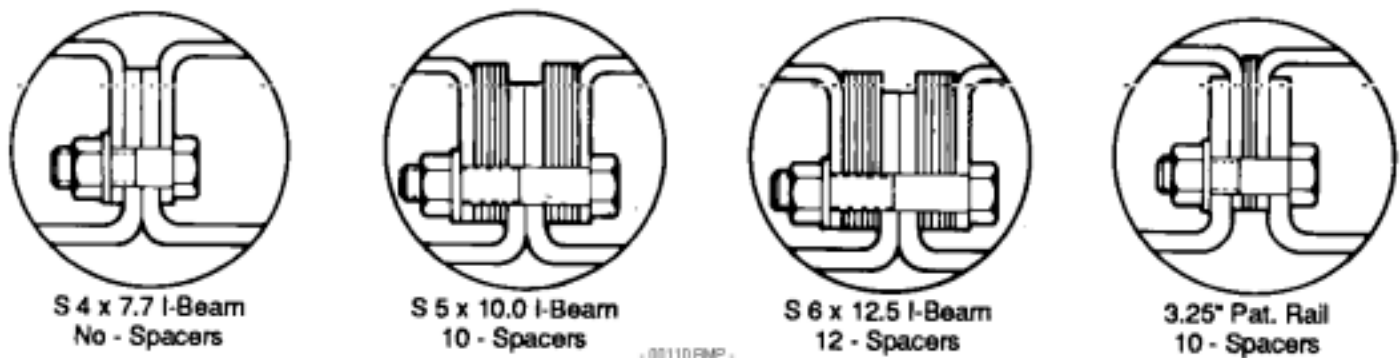

C. Lead car

The lead car is designed to lead the festoon system by the use of the customer outrigger. Pipe or bar stock under 1.25 O.D. is fastened to the equipment and positioned in the center of the tow box and lead car. When the tow bar is centered inside of the tow box it is free to move, eliminating loads on the festoon system caused by movement on the towing unit.

D. Track clamp

The track clamp should be installed to the underside of I-beam using mounting bolts and beveled washers provided. The minimum distance from the end of the I-beam to the center line of the track clamp, shall be one-half the length of the carrier--or dimension B in Figure 4.

Figure 4

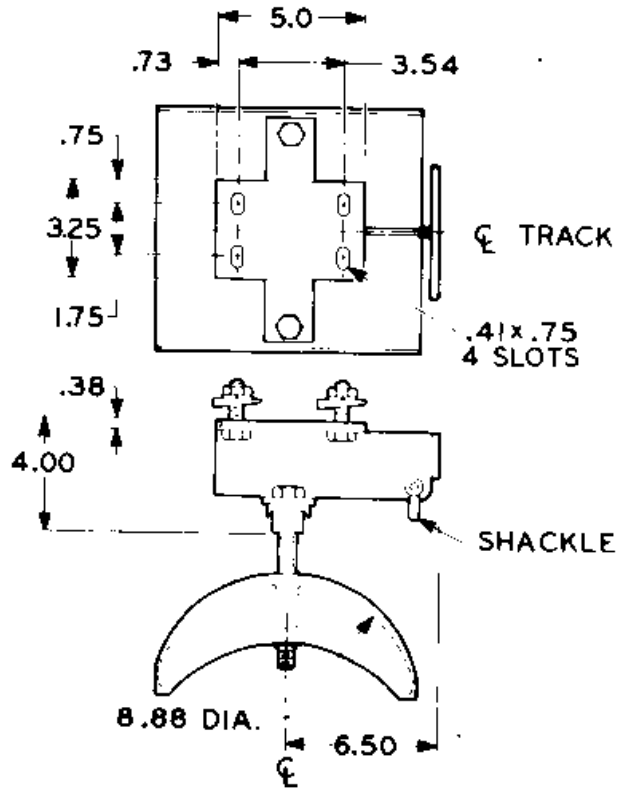

- 00112.BMP -

TRACK CLAMP

Model Number	"B"
67xx	3.50
60xx	5.00
63xx	6.500

E. Loop depth and loop mark

The loop depth (LD) is the distance from the top of the saddle to the bottom of the hanger cable in the storage position.

The marking length (LM) is the amount of cable required between the center lines of two carriers. To determine the marking length (LM), use the chart below.

Figure 5

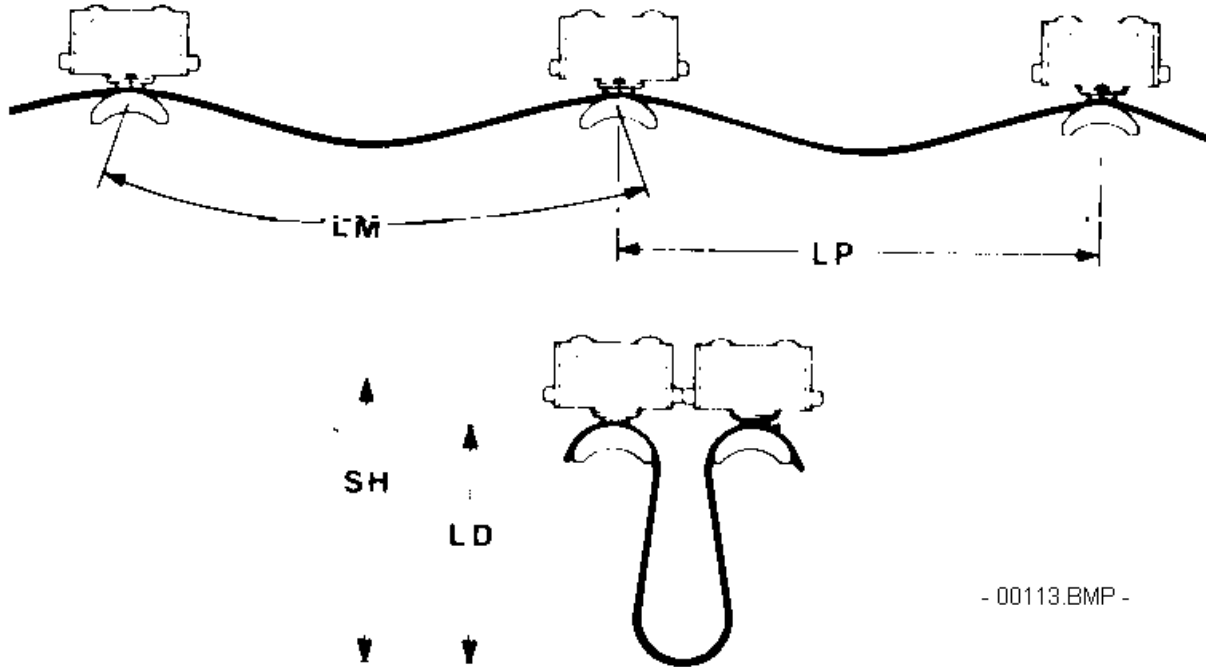

LD (in.)	36	42	48	54	60	66	72	78	84
SH (in.) *	40.25	46.25	52.25	58.25	64.25	70.25	76.25	82.25	88.25
LP (in.)	5.83	6.71	7.68	8.57	9.46	10.35	11.32	12.21	13.10
LM (in.)	77	87	102	113	125	137	150	161	173
TC (in.)	67	78	90	101	112	123	135	146	157

SH-system height, LD-loop depth, LP-loop pitch, TC-tow cable, LM-loop mark

* May be used as clearance dimension

F. Tow cable assembly--when required

Tow cables are recommended on systems with 100 feet of active travel.

Tow cable (TC) is shipped as an assembly complete with fixed loop ends and mounting hardware. The length is determined by the chart above. To install, remove pins from car--as shown in Figure 6--and place tow cable between side plates of car and replace pins into car. When hooking tow cable to track clamp, use shackle to connect tow cable to clamp. See Figure 4.

Figure 6

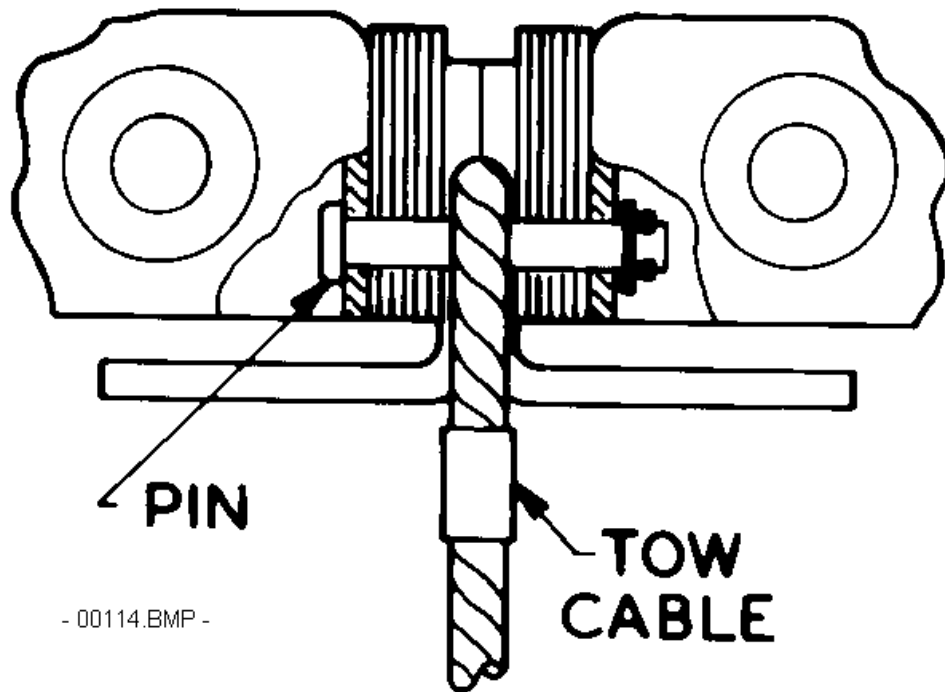

G. Round cable installation

Carriers are designed with a thick soft clamp pad to accommodate differences in cable or hose diameters up to 0.25 inches. In instances where variances do exceed 0.25 inches, a saddle clamp must be used to secure the smaller cable or hose in position. See Figure 7.

When laying cable/hose on saddle, place heavy cable/hose in center of saddle with smaller cable/hose on outside of saddle.

Figure 7

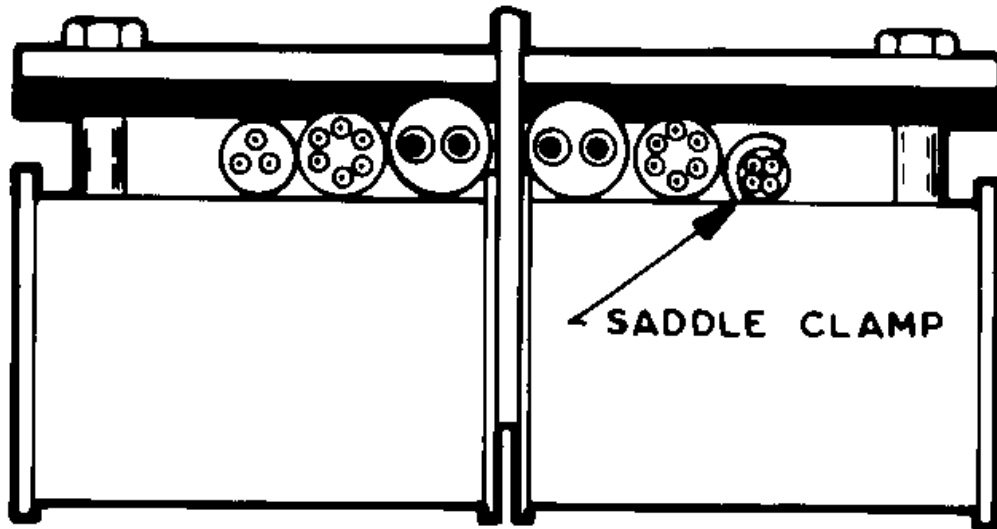

H. Loop organizers

On a round cable/hose festoon system, cable/hose has a natural tendency to twist. The twisting can be minimized by clamping them together with loop organizers. Each cable/hose loop between cars requires two loop organizers. See Figure 8.

Figure 8

- 00116.BMP -

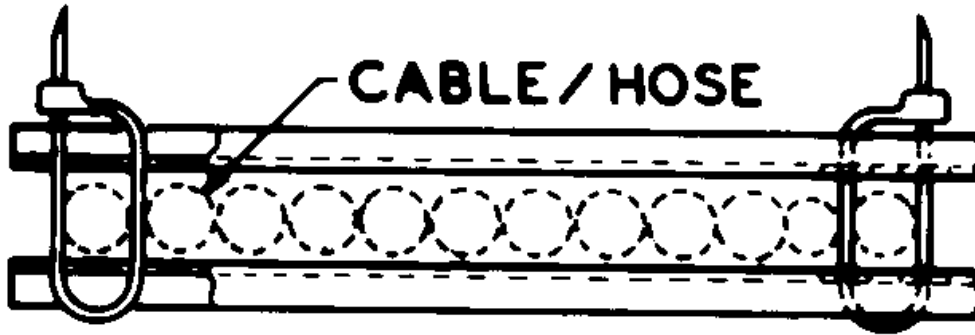

Aero-Motive Company

W A Woodhead Industries Inc. Subsidiary
5688 ML Avenue East
PO Box 2678
Kalamazoo, MI 49003-2678
(800)-999-8559
(800) 333-6119 FAX

Aero-Motive (UK) Limited

W A Woodhead Industries Inc. Subsidiary
9 Rassau Industrial Estate
EBBW Vale Gwent NP3 5SD
United Kingdom
(0495) 350436
(0495) 350877 FAX

Woodhead Asia PTE LTD

W A Woodhead Industries Inc. Subsidiary
8 Chia Ping Road #05-09/10
JTC Flatted Factory
Singapore 619973
(65) 261-6533
(65) 261-3588 FAX

Woodhead Canada LTD.

W A Woodhead Industries Inc. Subsidiary
1090 Brevik Place
Mississauga Ontario
L4W 3Y5 Canada
(905) 624-6518
(905) 624-9151 FAX